

## reflecta Superia

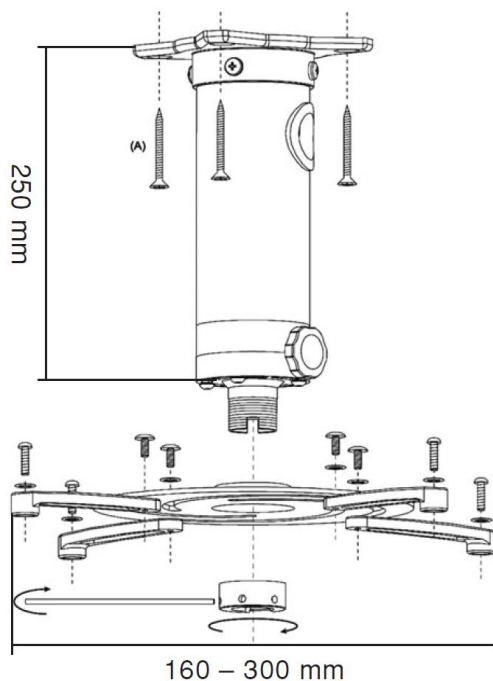
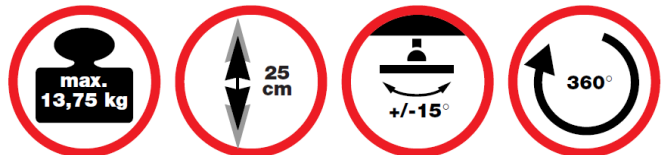

### Product information:

- Universal ceiling mount for video projectors
- Steel construction with electrostatic powder coating
- Cable management
- Max loading weight 13,75 kg
- Fixed height of 25 cm
- Neigbar +/-15°
- 360° Rotation

Art.Nr.: 23058  
 EAN: 4005039230585

Specifications subject to change without notice



**reflecta gmbh**  
 Merkurstrasse 8  
 D 72184 Eutingen  
 Phone: +49 (0) 7457 9465-60  
 Fax: +49 (0) 7457 9465-72  
 e-mail: [mail@reflecta.de](mailto:mail@reflecta.de)  
 http: [www.reflecta.de](http://www.reflecta.de)